

Sanfield Ecobox System is a smart and easy to install method of maintaining continuity of reinforcement at construction joints in concrete. It consists of a galvanised steel casing and pre-bent bars that are housed within the casing and are enclosed by a protective cover.

ADVANTAGES OF ECOBOX

- Unique shape guarantees a tongue and groove connection between the two concreting phases.
- The edges on the sides prevent displacement of the casing when the lid is removed, improving the quality of the anchoring.
- Cardboard inserts, perfectly adapts to the shape of the casing, preventing the penetration of cement slurry along the sides of the casing.
- More safe installation supported by the cardboard lid (no more hand cutting).
- No unfriendly waste of material.
- Ecobox saves costs, time and eventually money.

ADVANTAGES OF COUPLER BOX

- Unique Solution for future Coupler Reinforcement
- Smart work suitable for Slip & Jump Form works
- Ideal for precast connecting structures.

TECHNICAL PROPERTIES

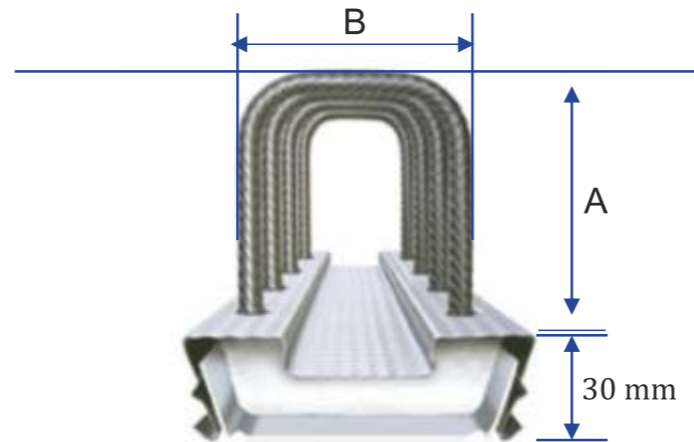

The lengths of the steel casings are 1.20 and 2.40Mtr. respectively.

The standard measurements of the stirrups are shown below.

(Dimensions A and B) are available to order.

- The two commercial* standard length of Ecobox are 1.20 and 2.4 Mtr respectively.
- The width of the casing depends on the type of casing suitable to slab width
- The height of the metal casing is 30 mm approx

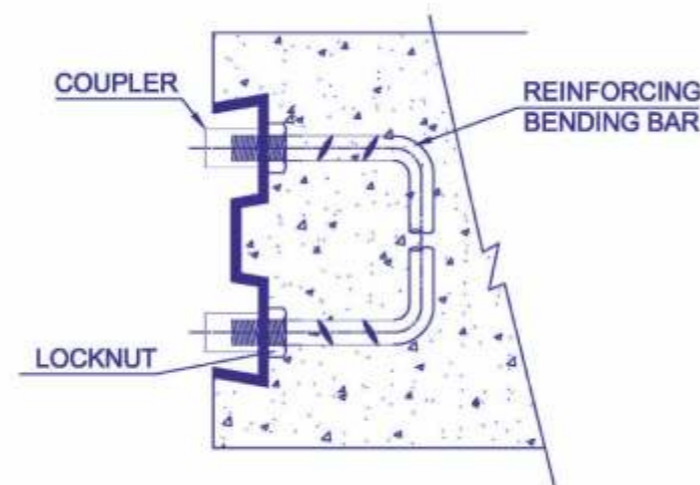

INSTALLATION PROCEDURE

1. Check that the chosen dimensions of the Ecobox correspond with the required concrete cover of the second concreting phase. Ensure that the thermocol inserts are in.



2. Fix the Ecobox to the form work or to the Reinforcements, if not nailed to formwork.



3. Cast the concrete in the first phase.

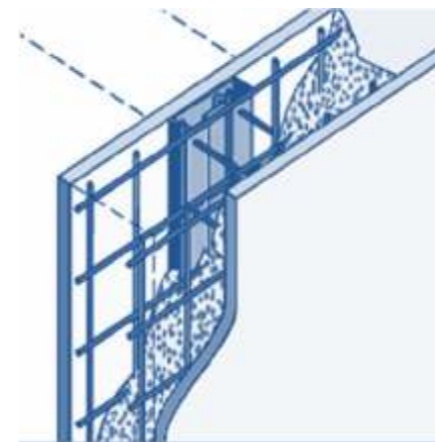

4. Remove the cardboard lid after removing the form work.

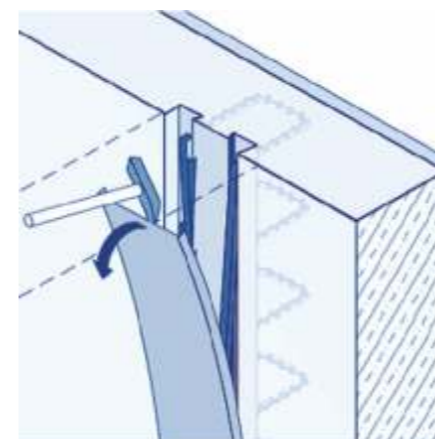

5. Check that the stirrups are completely clean.



6. Bend the bars out. It is advisable to use a bending tool to avoid distortion of bayonet.

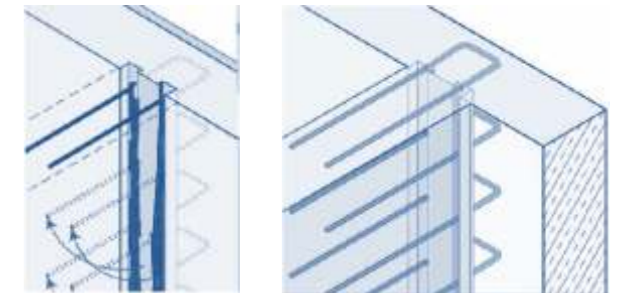

CENTERING OF ECOBOX

- The Ecobox can cope with a curve because of the saw cuts on the sides of the casing.
- Obviously the starter bars should not be cut or damaged.
- The openings in the casing must be carefully sealed before the Concrete is cast.



“The only rebar casing which can realise a tongue and groove connection between the two concreting phases.”

S TYPE

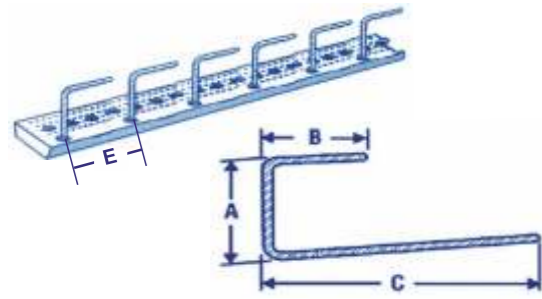

S Type Ecobox in development length of bar for spacing.

Type of Eco Box(X)	Steel Diameters mm.	Maximum Development length of Bar(C) for spacing (E)				
		100	150	200	240	300
45 S	6			1000	1100	1100
	8		500	700	800	1000
	10		390	500	600	
60 S	8		800	1000	1100	
	10		700	800		
90 S	10	600	900	1050		
	12	480	700	950		

DS TYPE

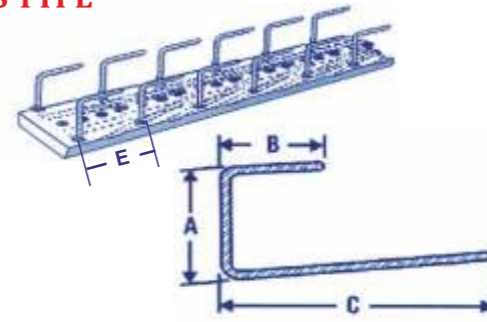

DS Type Ecobox in development length of bar for spacing.

Type of Eco Box(X)	Steel Diameters mm.	Maximum Development length of Bar(C) for spacing (E)				
		100	150	200	240	300
120DS	8		600	600		
	10		600	600		
	12	310	480	640		
160DS	8		600	600		
	10		600	600		
	12	480	600	600		
190DS	8		600	600		
	10		600	600		
	12	600	600	600		
230DS	8		600	600		
	10		600	600		
	12	600	600	600		

D TYPE

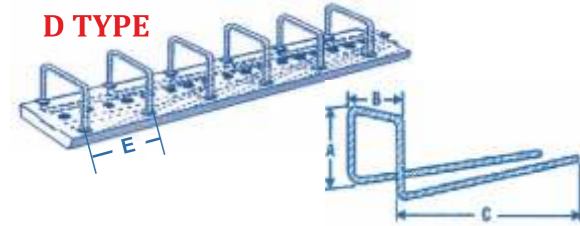

D Type Ecobox in development length of bar for spacing.

Type of Eco Box(X)	Steel Diameters mm.	Maximum Development length of Bar(C) for spacing (E)				
		100	150	200	240	300
90D	6		750	800	900	1000
	8		450	600	700	800
	10		390	500		
120D	6		800	1000	1100	
	8		500	600	750	1000
	10		400	650		
160D	6		1200	1200		
	8		900	1100		
	10		700	800		
	12		600	750		
190D	8		600	600		
	10		600	600		
	12		600	600		
230D	8		600			
	10		600	600		
	12		600			

DX TYPE

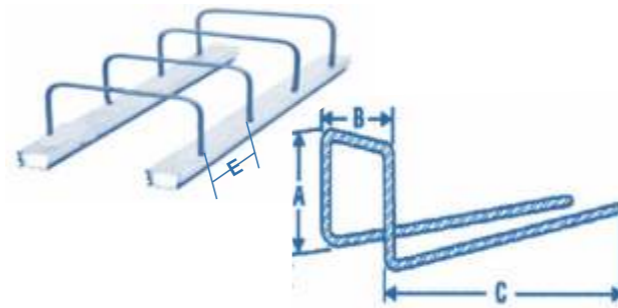

DX Type Ecobox in development length of bar for spacing.

Type of Eco Box(X)	Steel Diameters mm.	Maximum Development length of Bar(C) for spacing (E)				
		100	150	200	240	300
45 DX	6			1000	1100	
	8		500	700	800	
	10		390	500		
60 DX	8		800	1000	1100	
	10		700	800		

SANFIELD

SMART REINFORCEMENT CONNECTIONS



Sanfield [India] Limited.



MUMBAI OFFICE	BHOPAL (Head Office)	BHOPAL OFFICE
Hind Saurashtra Industrial Co-op. Society Ltd, Unit No. b-17 Marol Naka Andheri Kurla Road, Andheri (e), Mumbai-400059 Tel : 022-28500275/276 sanfieldmumbai@sanfieldindia.in	13-A & 12-D - Sector-d Industrial Area, Govindpura, Bhopal - 462 023, India. Tel : 0755-4233535(30 Lines) 26062661/662 Fax : 0755-4270730, sanfield@sanfieldindia.in	B-7, 2 nd Floor, South Extension - II, New Delhi - 110 049 Tel: 011- 46026903 sanfielddelhi@sanfieldindia.in
AHMEDABAD	CHENNAI	HYDERABAD
sanfieldahmedabad@sanfieldindia.in +918980314418	sanfieldchennai@sanfieldindia.in +919840165062	sanfieldhyderabad@sanfieldindia.in +919977271110
BANGALORE	sanfieldbangalore@sanfieldindia.in +9180500 10502	

ECOBIX & COUPLER BOX.

Sanfield [India] Limited.

